

# GENERATING SET GE 12000 HZDT

The images are for reference



## FEATURES

- Low oil pressure automatic engine shut down and high temperature
- A recessed panel protects the sockets
- Protective frame
- Automatic voltage regulation "AVR"
- Circuit breaker
- ELCB-GFI (Ground Fault Interruptor)
- Meets EC directives



air cooled



diesel



three-phase



electric start

## POWER RATINGS

* Stand-By three-phase power (LTP)	12 kVA (9.6 kW) / 400 V / 17.3 A
* PRP three-phase power	11 kVA (8.8 kW) / 400 V / 15.8 A
* PRP single-phase power	6 kVA/kW / 230 V / 26 A
Frequency	50 Hz
Cos φ	0.8

\* Output powers according to ISO 8528-1

## DEFINITION

Valid declared powers up to the followings environmental conditions: temperature 25°C, altitude 100 meters above sea level)

**LTP power: stand-by power:** Maximum available power for use with variable loads for a yearly number of hours limited at 500 h. No overload is admitted.

**PRP power:** continue power with variable loads. Maximum power for use with variable loads for a yearly unlimited numbers of hours.

**COP power:** continuous power with constant load. Maximum power for use with constant loads for a yearly unlimited numbers of hours.

## ENGINE 3000 RPM

### 4-STROKE, DIRECT INJECTION

Model	HATZ 1D90
* Stand-By net power	11.2 kWm (15.2 hp)
* PRP net power	10.2 kWm (13.9 hp)
* COP net power	/
Cylinders / Displacement	1 / 722 cm <sup>3</sup>
Bore / Stroke	104 / 85 (mm)
Compression ratio	10.5 : 1
BMEP (Brake Mean Effective Pressure : LTP - PRP)	/
Speed governor type	Meccanico
<b>FUEL CONSUMPTION</b>	
110 % (Stand-by power)	3.6 lt./h
100 % to PRP	3.3 lt./h
75 % to PRP	2.5 lt./h
50 % to PRP	1.6 lt./h
<b>COOLING SYSTEM</b>	
Total system cap. - only engine	/
Fan air flow	10.6 m <sup>3</sup> /min.
<b>LUBRICATION SYSTEM</b>	
Total oil system capacity	/
Oil capacity in sump	1.9 lt.
Oil consumption at full load	< 0.028 kg./h

### EXHAUST SYSTEM

Maximum exhaust gas flow	/
Max. exhaust gas temp.	/
Maximum back pressure	/
External diameter exhaust pipe	/
<b>ELECTRICAL SYSTEM</b>	
Starter motor power	2 kW
Battery charging alternator cap.	16 A
Cold start	/
With cold start aid	- 10°C
<b>AIR FILTER</b>	
Combustion air flow	1.08 m <sup>3</sup> /min.
<b>HEAT REJECTED AT FULL LOAD</b>	
To exhaust system	/
To water and oil	/
Radiated to room	/
To charge cooler	/

## ALTERNATOR

SYNCHRONOUS, THREE-PHASE, SELF-EXCITED, SELF-REGULATED, BRUSHLESS		
	WITH AVR	WITHOUT AVR
Continuous power	11.5 kVA	
Stand-by power	12.5 kVA	
Three phase voltage	380-415 Vac	400 Vac
Frequency	50 Hz	
Cos φ	0.8	
Model A.V.R.	HVR 10	/
Voltage regulation acc.	± 1 %	± 4 %
Sustained short circuit current	≤ 3 In	
Transient dip (100% load)	< 15 %	
Recovery time	/	
Efficiency at 100% load	83.5 % (400V - Cos φ 0,8)	83 % (400V - Cos φ 0,8)
Insulation	Classe H	
Connection - Terminals	Stella - N°6	
Electromagnetic compatibility ( R.F.I. suppr.)	/	
Waveform distortion - THD	< 4 %	< 5 %
Telephone interference - THF	/	

REACTANCES (11.5 KVA - 400 V)		
Direct axis synchronous - Xd	239 %	280 %
Direct axis transient - X'd	19 %	21 %
Subdirect axis transient - X''d	4.6 %	5,8 %
Quadrature axis synchronous - Xq	130 %	155 %
Quadr. axis subtransient - X''q	/	
Negative sequence - X2	/	
Zero sequence - X0	/	
TIME CONSTANTS		
Transient - T'd	46 ms	40 ms
Subtransient - T''d	6 ms	6 ms
Open circuit - T'do	580 ms	530 ms
Armature - Ta	/	
Short-circuit ratio Kcc	0.72	0.62
IP protection degree	IP 23	
Cooling air flow	0.082 m³/sec.	
Coupling   Bearing	Diretto J609b - N°1	

## GENERAL SPECIFICATIONS

Fuel tank capacity	18 lt.
Running time (75% to PRP)	7.2 h
Starter battery	12 Vdc -37Ah / 330A CCA(EN)
IP protection degree	IP 23

Acoustic power LwA (pressure LpA)	105 dB(A) (80 dB(A) @ 7m)
Performance class (ISO 8528)	G2

## CONTROL PANEL

- Start and stop engine key
- Low oil pressure warning light with shutdown
- High engine temperature warning light with shutdown
- Battery charge warning light fault
- Digital multifunction meter: Voltmeter - Frequncymeter - Total Hoursmeter - Partial Hoursmeter (resettable)
- Circuit breaker
- ELCB-GFI (Ground Fault Interruptor)
- Output sockets : 1x 400V 32A 3P+N+T CEE  
2x 230V 16A 2P+T CEE
- Output sockets (schuko version): 1x 400V 32A 3P+N+T CEE  
2x 230V 16A 2P+T Schuko
- Earth terminal (PE)



# WEIGHT - DIMENSIONS AND ACCESSORIES

GE 12000 HZDT



### DRY WEIGHT MACHINE:

- 220 Kg

Generating set pictured may include optional accessories.



### DIMENSIONS DRAW (mm)

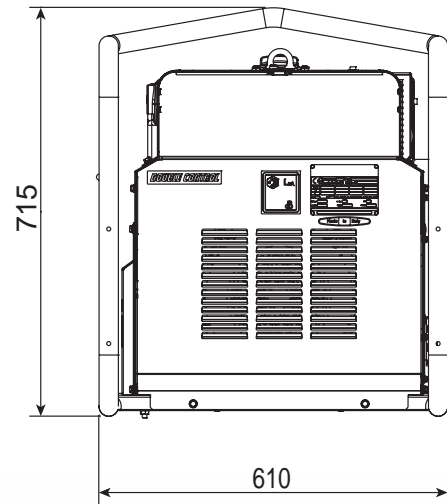
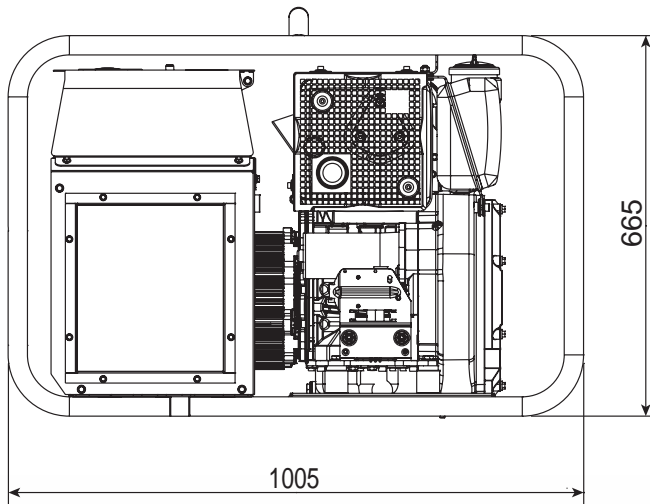

### OPTIONS ON REQUEST

- Earthing
- Trolley CTM 14



### VERSIONS ON REQUEST

- SCHUKO Version



### FACTORY INSTALLATION OPTIONS

- /

## GENERAL INFORMATION

### COMPLIANCE GENERATING SETS WITH EC DIRECTIVES AND STANDARDS

- 2006/42 / EC (Machines Directive)
- 2014/35 / EU (Low Voltage Directive)
- 2014/30 / EU (EMC Directive)
- 2000/14 / EC (Directive Acoustic Emission for machines for use outdoors)
- ISO 8528 (Reciprocating internal combustion engine driven alternating current generating sets)



ISO 9001:2015 - Cert. 0192

### WARRANTY

All devices are covered by the manufacturer's warranty.

The company reserves the right to change this specification without notice. For further information please contact the sales department.

© MOSA - Viale Europa, 59 - 20090 Cusago (Milano) - Italy - phone +39-0290352.1 - fax + 39-0290390466 E-mail: info@mosa.it Web site: www.mosa.it

